

Power

www.pelmag.com

# PEI

Power Engineering  
INTERNATIONAL

Volume 2001

**POWER-GEN  
International 2001:**  
Your PEI pull-out guide  
to Las Vegas

**Is coal making a  
comeback?**

# Equipment Roundup

## Advanced technology turbine bypass system

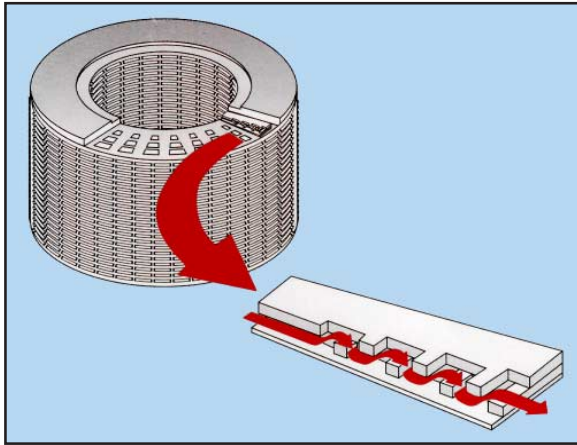

AES now uses this turbine-bypass system in most of their new power plants

When the new 705 MW combined cycle gas turbine AES Ironwood power plant near Lebanon, Pennsylvania, USA recently went on-line, AES had taken into account the absolute criticality of its turbine-bypass system design and selected advanced technology valves for all stages of this severe steam power generation service.

A few years ago, the high pressure (HP) feedwater control valves and manually operated HP and reheat superheater drain valves with maximum  $\Delta P$ s of 115 bar failed at their 688 MW Medway Power Ltd., plant in the UK. The failure of these drilled-hole, cage-guided control valves was due to excessive trim exit kinetic energy (or velocity head –  $H_v$ ). The replacement valve trim used takes full advantage of multi-stage-pressure reduction technology to severely limit this  $H_v$ .

Since then, AES has used this design technology in critical combined cycle, turbine bypass systems in most of its new power plants. In fact in

the last five years or so, this critical-service, multistage pressure-reduction technology with severely limited  $H_v$  has been utilized internationally in five AES combined cycle plants ranging from the 230 MW AES Barry power Plant in Wales up to this 705 MW AES Ironwood power plant in Pennsylvania.

### Turbine Bypass System

The turbine-bypass system at AES Ironwood consists of two, 100 x 250 mm HP steam-bypass-to-cold-reheat valves, two 400 x 400 mm low pressure (LP) steam-bypass-to-condenser, and two 640 x 889 mm hot-reheat-steam-bypass valves to the condenser, with an associated desuperheating spraywater control valve.

The HP bypass-to-cold reheat valves are designed for steam flows up to 70 kg/s at maximum inlet pressures of 130 bar[a] and  $\Delta P$ s of 115 bar at 570°C. The LP bypass-to-condenser valves are designed for steam flows up to 11 kg/s at maximum inlet pressures of 4 bar[a] and  $\Delta P$ s of 3 bar at 27°C.

The hot reheat bypass-to-condenser valves are designed for flows up to 95 kg/s at maximum inlet pressures of 30 bar[a] and  $\Delta P$ s of 29 bar at 570°C.

### Advanced Technology

Because of the high  $\Delta P$ s experienced with these HP bypass-to-cold-reheat valves and in their associated desuperheating spraywater control valves, these valves use the same advanced technology multistage pressure-reduction trim, as did the retrofitted and replacement Medway valves. In addition, AES now incorporated a recently developed steam-assisted desuperheating nozzle design that provides supersonic atomized steam with compound-swirl, steam-plume shaping which maintains even, consistent temperature control and reduces wear and damage to downstream piping.

To assure multistage pressure reduction in the hP bypass-to-cold-reheat bypass valves and their associated spraywater control valves, their design incorporates a stack of tortuous-path punched disks that force a series of right-angle, pressure reducing flow turns. In this technology the trim-exit kinetic energy, or velocity head ( $H_v = PV^2/2g$ ) is held to less than 4.8 bar to control potential noise and vibration and eliminate the potential for their damaging effects.

In addition, each disk incorporates a pressure-

equalizing ring (PER) on its inside diameter to ensure that equal pressure acts radially around the circumference of the plug at any position in its stroke. This design keeps the plug centered at all loads, thus preventing plug vibration.

LP bypass-to-condenser valves and the hot-reheat bypass-to-condenser valves incorporate such design features as a small drilled-hole cage design which produces a frequency that results in low noise levels as well as multiple, integral spraywater nozzles to eliminate the need for additional piping sections and effective means to assure rapid steam dispersion.

AES has recently purchased the turbine-bypass system arrangement for another 720 MW combined cycle plant in the USA scheduled to start-up in the near future.

### Reader Reply Number 82

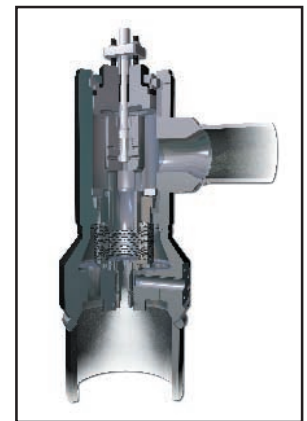

The new 705 MW AES Ironwood plant will use the new technology

Peter S. Norgoet, Plant Manager AES Ironwood, Lebanon, Pennsylvania, USA

Graham Clark, Senior Engineer CCI, Rancho Santa Margarita, California, USA