

Gas Letdown Valves

Solution Found To Chronic Trim Damage



Fig. 1: Single-stage, pressure-reducing valve trim severely damaged by high-velocity gas flow containing corrosion products.

by Paul A. Smirl, Manager, Design Engineering Control Components Inc., Rancho Santa Margarita, CA, and T.W. Edwards, Consultant, Sun City, CA

For some time, 2-inch single-stage gas-pressure letdown valve trim at a large Mideast oil and gas production facility suffered severe erosion damage, (Fig. 1), and experienced noise/vibration problems both within the valves themselves and the downstream piping.

It was determined that the trim erosion which caused the problem (Fig. 1) was due to high oxide corrosion products from the upstream piping passing at high velocity (1,020 ft/sec) through the single-stage, drilled-hole-cage valve trim. This was also the source of the noise/vibration problems.

Since it takes into account fluid density, it has been established that velocity head ($V^2/2$) is a better criterion than just pure fluid velocity in judging design adequacy in pressure-reducing valves. It is very useful in eliminating the destructive effects of high fluid velocity and noise/vibration problems. In this case, the actual velocity head equaled 360 psi. For these reasons, it was decided to replace these single-stage pressure-reduction valves with multi-stage pressure-reduction valves capable of limiting this high velocity.

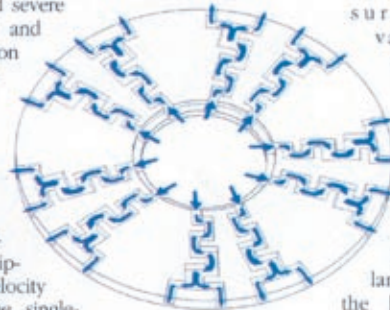

Fig. 2: A typical tortuous-path disk.

The multi-stage, pressure-reducing valves are usually designed with a maximum trim exit velocity head of 70 psi for gases. However, in this particular application, largely because of the hard iron-oxide corrosion products in the inlet gas flow, it was

decided to reduce the initial design velocity head of 40 psi further to a final design value of 30 psi. This produced a trim outlet velocity of only 294 ft/sec - a very con-

Valve Operating Conditions

Gas Flow Range Per Valve:
lb/hr.....16,200 to 28,800

Inlet Pressure:
Psig.....455 to 490

Outlet Pressure:
psig.....275

Differential Pressure:
psig.....180 to 214

Gas Temperature:
25°C; 77°F

servative value - only about 30 percent of the velocity in the original single-stage, pressure-reducing valves.

Because of the short delivery time needed, and more important because of the limited face-to-face dimension required by the existing piping, normal cast steel valve bodies were precluded. Therefore, the valve bodies were machined out of forged, A105 carbon-steel bar stock, (Fig. 2).

For added protection against possible erosion damage in the valve seat area, under-the-plug flow through the valve was used. And for improved resolution, the valve stem stroke was increased from 2 inches to 3.5 inches. The valves are a 600 A

Fig. 3: Valve side elevation showing the forged-steel body.

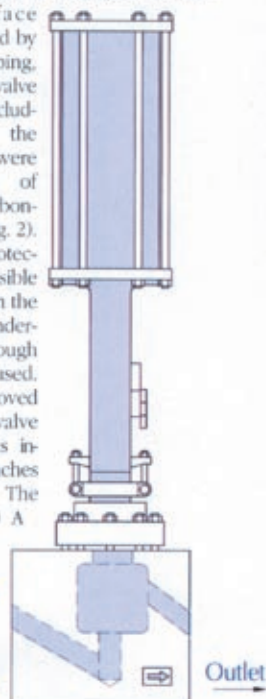

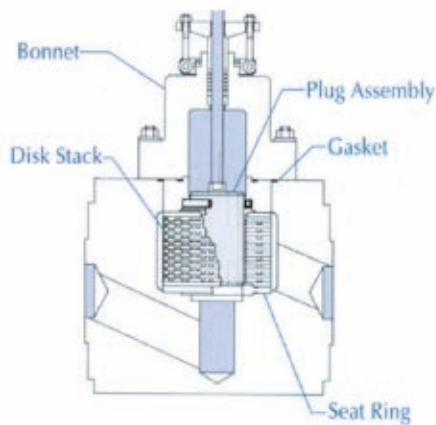

Fig. 4: Valve body sectional view.

NSI design, and the raised-face flange and bolt circle drilled into the forged valve bodies were designed to match the existing piping. Seat leak-

age is in accordance with ANSI/FCI 70-2, Class V.

The new pressure-reducing valves, (Fig. 3), incorporate a tortuous flow path. That is, pressure energy is dissipated at a controlled velocity head through 14 right-angle turns in each disk in the stack of individual disks. These valve trim disks, (Fig. 4), are electric-discharge machined. The stack of disks surrounds the plug throughout its stroke. In addition, the disk stack incorporates a pressure-equalizing ring on its inside diameter to ensure equal pressure acting radially on the valve plug at all times. This eliminates vibration that could occur because of rapid plug radial movement.

This tortuous-path velocity-control design limits noise levels to below 85 dBA at 3 feet. This low noise level also serves to reduce valve and piping vibration to acceptable levels.

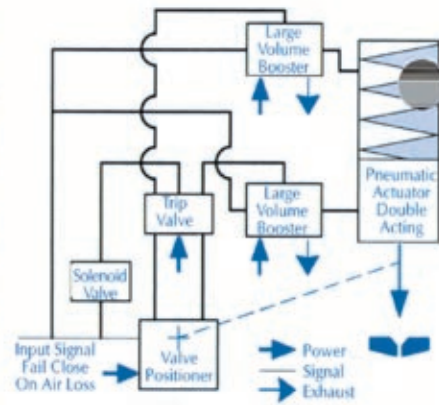

Fig. 5: The control schematic.

Air supply to the standard pneumatic actuators is 50 to 100 psig and the signal is 3 to 15 psig. The failure position is closed. **P&GJ**