

# SERIES 810S SINGLE SEATED VALVE

---

The series 810S single seated valve is developed for low pressure application on liquids, steam and gases. The valve offers excellent performance at a competitive price, so it is ideally suited for general flow control of most fluids. Since our 810S single seated valve is top guided, it is less prone to vibration than the top and bottom guided valve thanks to a reduced plug mass. In addition, the fluid passage of our top guided valve is more streamlined than other top and bottom guided valve designs resulting in a higher flow capacity.

The 810S valve provides reliable performance and cost effectiveness that will surely satisfy your control requirements.

The 810S valve is available in size 1/2" - 4", ANSI 150-900 classes, with either flanged or welding-end connections.

## Features

**High Capacity:** Streamlined body minimizes flow resistance and increases flow capacity.

**Tight Shutoff:** ANSI leakage class IV, V and VI are available to meet application requirements.

**Easy Maintenance:** Top-entry design for easy maintenance.

**Stable Operation:** Heavy duty guiding provides stable operation of the plug.

**Less Spare Parts Requirements:** Fully interchangeable parts ensure minimum spare parts requirements.

## Specifications

<b>Valve size:</b>	1/2" to 4"
<b>Ratings:</b>	ANSI Class 150, 300, 600 and 900
<b>End Connections:</b>	Flanged End, Welding End
<b>Materials:</b>	See Table 1 on Page 3
<b>Port Sizes:</b>	Full or reduced
<b>Flow Characteristic:</b>	Equal percentage, Linear or Quick open
<b>Seat Leakage:</b>	Standard-ANSI Class IV Option-ANSI Class V or VI
<b>Dimensions:</b>	See Table 4 on Pages 6,7

## Quality Assurance/Quality Control

All Series 810S valves meet the ANSI B16.34 standard for "Valves - Flanged, Threaded, and Butt-welding End." This encompasses the dimensions, construction, testing and rating of all valves supplied. We also perform ANSI standard seat leakage and hydrostatic tests on every valve we build, and operability tests are run on each valve and actuator leaving our factory. Special tests are readily available to meet your specific project needs, including non-destructive testing of valve components and performance testing of actuator controls.

Table 1 Combination of 810S Body Assembly Materials

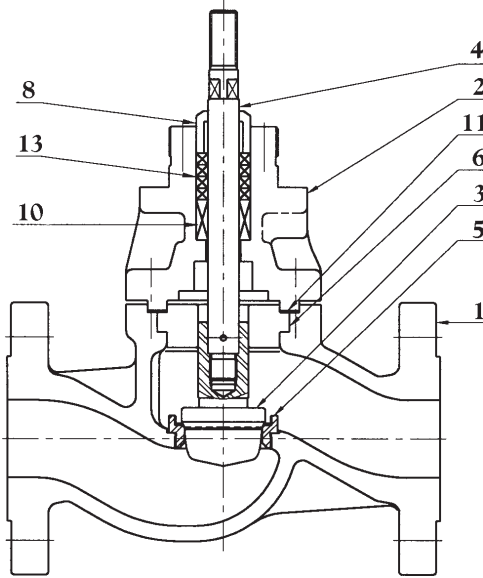

Figure 1  
Screwed-in Seat Type  
(ANSI Class 150~300)

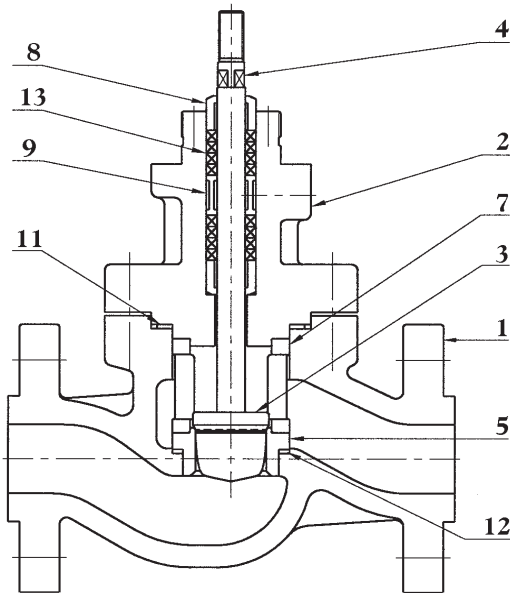

Figure 2  
Quick Change Trim Type  
(ANSI Class 150~900)

NO.	PART NAME	MATERIAL
1 2	Body Bonnet	A 216 WCB, WCC A 217 WC6, WC9 A 351 CF8, CF8M A 351 CF3, CF3M A 351 CN7M A 352 LCC HASTELLOY-C
3	Plug	316 SS 316 SS Stellite 420 SS
4	Stem	316 SS
5	Seat	316 SS 316 SS Stellite 420 SS 316 SS / TFE
6	Guide	316 SS 420 SS
7	Seat Retainer	316 SS
8	Packing Gland	316 SS / DU Bearing
9	Lantern Ring	316 SS
10	Packing Spacer	316 SS
11	Body/Bonnet Gasket	TFE (Filler) & SS or Graphite (Filler) & SS
12	Seat Gasket	
13	Packing Set	TFE (V-Packing) Glass-Filled TFE Graphite

\*Special materials are available - consult factory

Table 2 Flow Coefficients, Cv

Plug Size		1/8"			5/32"		1/4"			3/8"			1/2"	3/4"
Stroke	(inch)	0.4			0.4		0.8			0.8			0.8	0.8
	(mm)	10			10		20			20			20	20
Cv Value	Linear	0.04	0.06	0.08	0.15	0.2	0.4	0.6	0.8	1	1.5	3	5.2	9
	EQ%	-	-	-	0.15	0.2	0.4	0.6	0.8	1	1.5	3	5.2	9
	Quick open	-	-	-	0.2		0.8			3			5.6	10.5
Rangeability		20 : 1					30 : 1							

Plug Size		1"		1 1/4"		1 1/2"		2"		2 1/2"		3"		4"	
Stroke	(inch)	0.8	0.8	1.2	0.8	1.2	1.2	1.6	1.2	1.6	1.2	1.6	1.6	1.6	2
	(mm)	20	20	30	20	30	30	40	30	40	30	40	40	40	50
Cv Value	Linear, EQ%	16	24		33		50		70		80	100	120	170	
	Quick open	18.5	24	29	33	38	50	62	75	80	105	120	150	190	
	Rangeability	30 : 1													

\* Plugs which have a Cv less than 0.04 are available - consult factory

\* For special rangeability consult factory

**Equal Percentage Flow Chart**

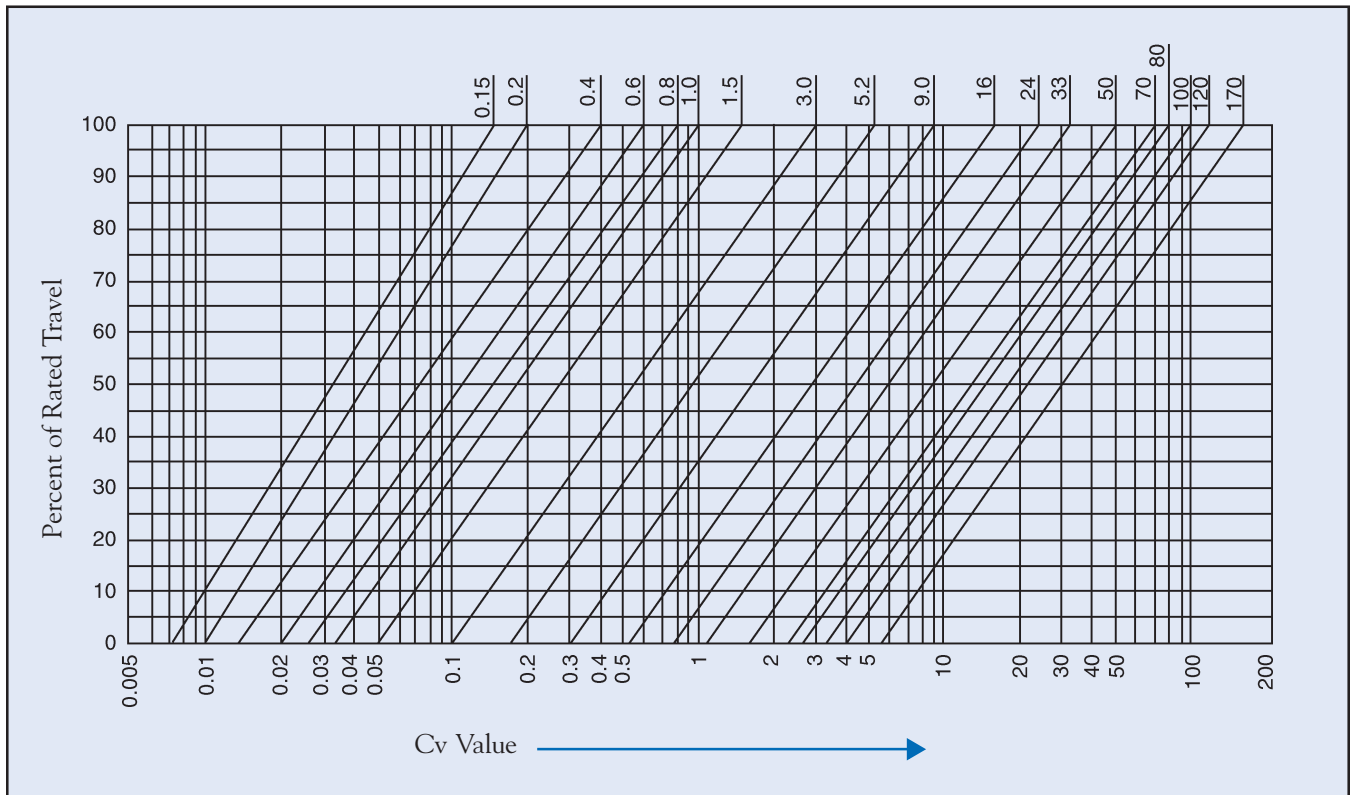

Figure 3

Table 3 Cv Table

EQ% Plug

Port Size	Stroke		Cv At Percent Open									
	(inch)	(mm)	100	90	80	70	60	50	40	30	20	10
5/32"	0.4	10	0.15	1.11	0.08	0.06	0.45	0.035	0.015	0.025	0.015	0.01
	0.4	10	0.2	0.15	0.12	0.08	0.06	0.045	0.038	0.025	0.019	0.013
1/4"	0.8	20	0.4	0.29	0.20	0.14	0.10	0.07	0.05	0.04	0.03	0.02
	0.8	20	0.6	0.43	0.30	0.22	0.15	0.11	0.08	0.06	0.04	0.03
	0.8	20	0.8	0.57	0.41	0.29	0.21	0.15	0.10	0.07	0.05	0.04
3/8"	0.8	20	1.0	0.17	0.51	0.36	0.26	0.18	0.13	0.09	0.07	0.05
	0.8	20	1.5	1.1	0.76	0.54	0.39	0.27	0.20	0.14	0.10	0.07
	0.8	20	3.0	2.1	1.5	1.1	0.77	0.55	0.39	0.28	0.20	0.14
1/2"	0.8	20	5.2	3.7	2.6	1.9	1.3	1.0	0.7	0.5	0.3	0.2
3/4"	0.8	20	9.0	6.4	4.6	3.2	2.3	1.6	1.2	0.8	0.6	0.4
1"	0.8	20	16	11	8.1	5.8	4.1	2.9	2.1	1.5	1.1	0.8
1 1/4"	0.8/1.2	20/30	24	17	12	8.7	6.2	4.4	3.1	2.2	1.6	1.1
1 1/2"	0.8/1.2	20/30	33	24	17	12	8.5	6.0	4.2	3.1	2.2	1.6
2"	1.2/1.6	30/40	50	36	25	18	13	9.1	6.5	4.6	3.3	2.3
2 1/2"	1.2/1.6	30/40	70	50	36	25	18	13	9.1	6.5	4.6	3.3
3"	1.2	30	80	57	41	29	21	15	10	7.4	5.3	3.8
	1.6	40	100	71	51	36	26	18	13	9.3	6.6	4.7
4"	1.6	40	120	86	61	43	31	22	16	11	7.9	5.6
	2.0	50	170	121	86	61	44	31	22	16	11	8

Table 4 810S Single Seated Body Dimensions

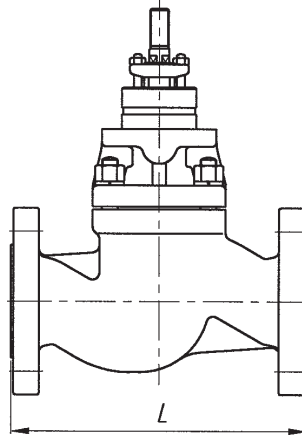
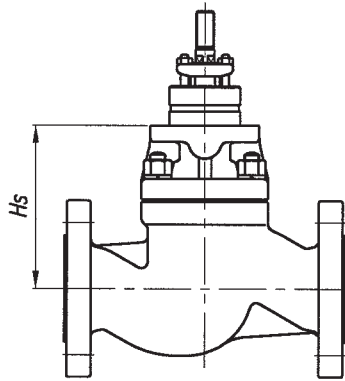

Figure 4

VALVE SIZE		L (Flanged End)			
(inch)	(mm)	ANSI Class 150	ANSI Class 300	ANSI Class 600	ANSI Class 900
1/2"	15	7.25/184	7.50/190	8.00/203	10.75/273
3/4"	20	7.25/184	7.62/194	8.12/206	10.75/273
1"	25	7.25/184	7.75/197	8.25/210	10.75/273
1 1/2"	40	8.75/222	9.25/235	9.88/251	13.12/333
2"	50	10.00/254	10.50/267	11.25/286	14.75/375
2 1/2"	65	10.88/276	11.50/292	12.25/311	16.12/410
3	80	11.75/298	12.50/318	13.25/337	17.38/441
4	100	13.88/352	14.50/368	15.50/394	20.12/511

VALVE SIZE		L (Welding End)			
(inch)	(mm)	ANSI Class 150	ANSI Class 300	ANSI Class 600	ANSI Class 900
1/2"	15	8.12/206	8.12/206	8.12/206	11.00/279
3/4"	20	8.25/210	8.25/210	8.25/210	11.00/279
1"	25	8.25/210	8.25/210	8.25/210	11.00/279
1 1/2"	40	9.88/251	9.88/251	9.88/251	13.12/333
2"	50	11.25/286	11.25/286	11.25/286	14.75/375
2 1/2"	65	11.50/292	11.50/292	12.25/311	16.12/410
3	80	12.50/318	12.50/318	13.25/337	18.12/460
4	100	14.50/368	14.50/368	15.50/394	20.88/530

- Notes:
1. All dimensions are for reference only
  2. All dimensions of flange end meet ISA standard
  3. For angle valve consult factory
  4. Welding End: 1) 1/2" - 2" = Socket Weld  
2) 2 1/2" - 4" = Butt Weld



Standard Bonnet  
Figure 5

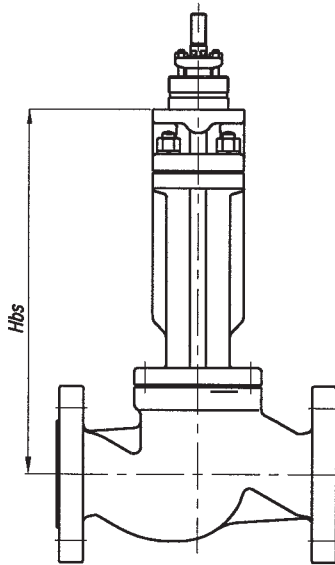

Bellows Bonnet  
Figure 6

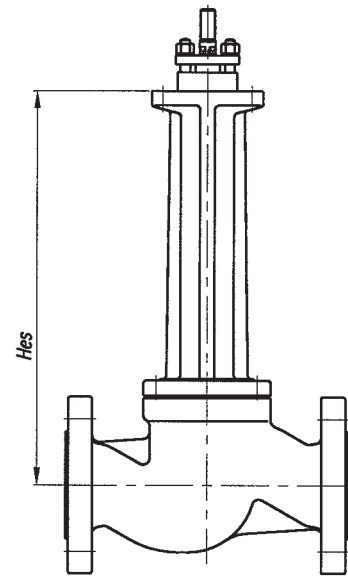

Extension Bonnet  
Figure 7

VALVE SIZE		ANSI CLASS 150,300					
		Screwed - in Seat Type			Quick Change Trim Type		
(inch)	(mm)	Hs	Hbs	Hes	Hs	Hbs	Hes
1/2"	15	4.5/114	11.1/281	10.0/255	4.8/122	11.8/300	9.8/250
3/4"	20	4.5/114	11.1/281	10.0/255	4.8/122	11.8/300	9.8/250
1"	25	4.5/114	11.1/281	10.0/255	4.8/122	11.8/300	9.8/250
1 1/2"	40	5.1/129	1.3/286	11.8/300	5.8/146	13.8/350	10.8/275
2"	50	6.1/155	14.8/376	16.6/422	6.3/159	15.0/380	13.4/340
2 1/2"	65	6.7/169	15.3/388	16.9/430	7.9/180	16.5/420	13.8/350
3"	80	8.4/214	19.1/485	17.9/485	17.9/455	8.1/206	17.3/440
4"	100	10.0/253	20.9/531	20.4/518	9.4/239	20.4/517	19.8/504

Valve Size		ANSI Class 600		ANSI Class 900	
(inch)	(mm)	Hs	Hes	Hs	Hes
1/2"	15	4.8/122	9.8/250	6.7/169	11.4/289
3/4"	20	4.8/122	9.8/250	6.7/169	11.4/289
1"	25	4.8/122	9.8/250	6.7/169	11.4/289
1 1/2"	40	5.6/146	10.8/275	7.5/190	13.8/350
2"	50	6.3/159	13.4/340	8.9/225	17.5/444
2 1/2"	65	9.8/250	14.4/366	10.2/260	18.9/480
3"	80	8.9/227	18.2/463	12/304	20.6/524
4"	100	11.2/285	20.9/530	13.6/345	23.6/600

Note: All dimensions are for reference only