



**CCI DRAG[®]
DA-90DSV
Attemperator**



- **Minimizes Leakage**
- **Handles High Thermal Stresses**
- **Enhanced Controllability**
- **Prevents Cavitation Damage**
- **Meets Common Face-to-Face Dimensions**
- **Low Maintenance Costs**
- **Less Erosion Damage**
- **High Plant Efficiency**



Figure 2: Illustrations of damage due to thermal cycling, often caused by poor attemperator performance.

CCI DRAG® DA-90DSV Attemperator

With each new operating season, the limits of interstage attemperators in Heat Recovery Steam Generators (HRSGs) are being tested. As plants search for the most economical operation, be it cycling daily or operating at reduced loads for extended hours, reliability and operability of the superheat (SH) and reheat (RH) interstage attemperators consistently come into question. Whether it is a constantly leaking attemperator that must be repaired or replaced every outage, or a more catastrophic failure like a boiler tube leak or a ruptured steam line, the headaches and frustrations associated with interstage attemperation are becoming all too familiar to plant managers, operators, and maintenance personnel.

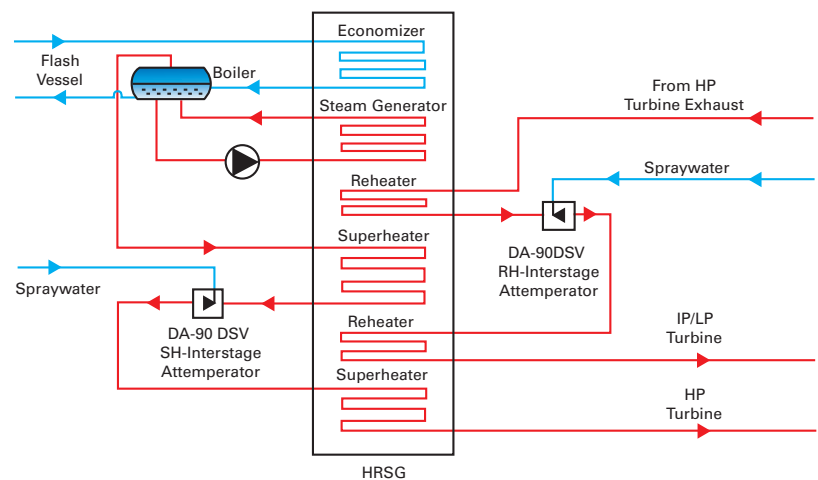

Figure 1: Typical HRSG schematic

Symptoms of Faulty Attemperators

Some of the first signs of trouble start with uncontrolled spraywater flow and leakage. Scheduled inspections often reveal:

- Damaged spray nozzles.
- Cracked attemperator housings.
- Damaged seals.
- Cracked steam pipes and boiler tubes.
- Cracked/broken thermal liners.

The root cause of most interstage attemperator problems can be traced to four main system/installation parameters:

- High pressure drop through the spraywater control portion of the attemperator.
- High thermal stresses caused by large temperature differences between the steam and the cooling water.
- Poor atomization of the cooling water leading to large amounts of unevaporated water in the steam line.
- Poor installation with short distances to downstream elbows, temperature sensors, or HRSG reentry points.



Figure 3: Cavitation damage on plug.

Faulty Attemperator Design

Many of the common interstage attemperator systems overlook several or all of the root causes of failure listed on the previous page. Such designs will lead to problems in your plant, it's only a matter of time! Consider the following:

Single Stage Pressure Drop – Problem

When using fixed speed pumps, the pressure drop in some interstage attemperator spraywater systems can reach levels greater than 2000 psi (133 bar). This high pressure drop will severely damage and prematurely wear a single stage control element causing wire draw, leakage, and cavitation damage (See Figure 3). The key to eliminating this root cause of failure is to incorporate **multiple stages of pressure drop** in a control valve trim. CCI's DRAG® Velocity Control Trim can easily package up to 20 stages of pressure drop in attemperator systems to handle the large pressure drop of the spraywater system.

Valve Trim in the Steam Flow – Problem

As allowable operating temperatures increase, interstage attemperators can see steam to spraywater temperature differences near 700 F (390 C). This high temperature difference in conventional attemperator designs will lead to high thermal stresses. An attemperator design, such as the one shown in Figure 4, that locates tight clearance control elements (i.e. valve trim) in an environment that sees these drastic temperature swings will fail. Common failures such as cracked attemperator bodies, cracked attemperator welds, cracked attemperator nozzles, stuck or seized plug and stem elements, and even packing leaks can all be attributed to a design that neglects to account for the high temperature difference in this application. To avoid these problems, location is the key. Tight clearance valve trim components should be moved out of the steam pipe and away from the hot steam temperatures.

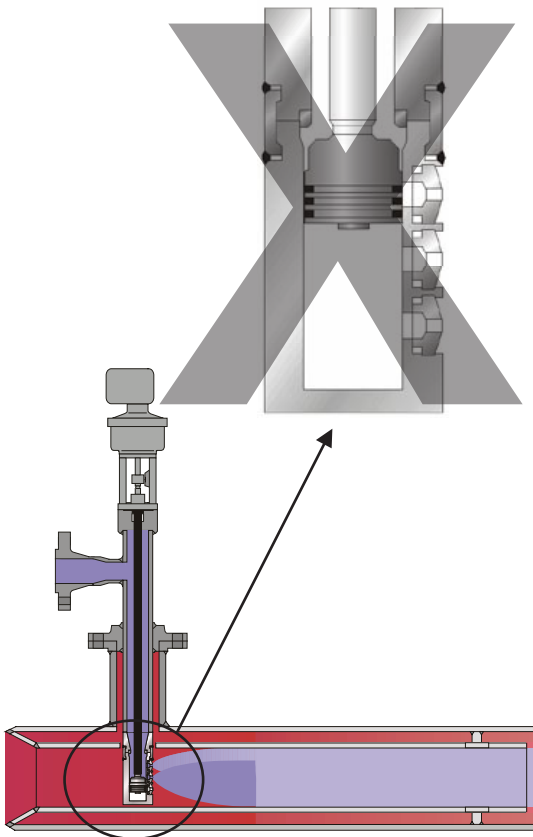
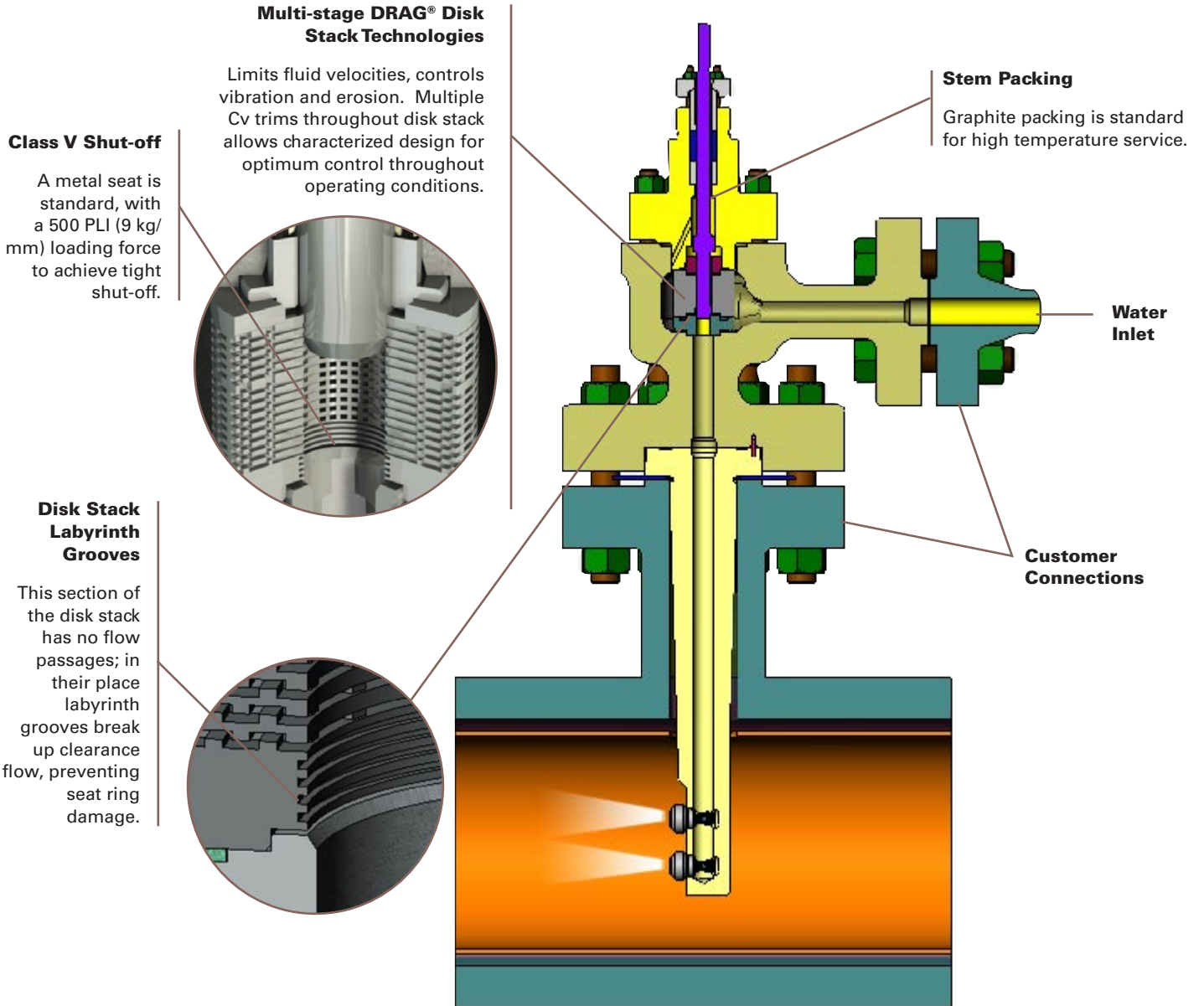

Figure 4: Section view of a conventional attemperator design.

Pressure Boundary and Tack Welds – Problem

Due to the nature of the application and the operation of today's HRSGs, interstage attemperators will always be exposed to thermal cycling. Welds, and the heat affected zones around them, are vulnerable to cracking when put through thermal cycles while also being exposed to high pressure loads and bending stresses. A properly designed interstage attemperator eliminates all welds by using a one-piece Chrome Moly forging, thus removing the risk of cracking in the attemperator body.

Problems	Solution
High pressure drop in a single stage	Use multiple stages of pressure drop in a DRAG® Velocity Control Trim
Expose attemperator to high thermal stresses by locating trim components in the hot steam pipe	Move the valve trim to a safer environment outside of the steam pipe and away from harsh thermal stresses
Use pressure boundary and tack welds	Eliminate all welds by using a one-piece Chrome Moly forging



CCI DRAG® DA-90DSV Attemperator

Benefits		DRAG® DA-90DSV	Competition
■	Provides the Valve Doctor Solution. CCI works with plant operators to improve plant performance, reliability and output.	✓	□
■	Prevents Cavitation Damage. CCI works in accordance with ISA guidelines to ensure cavitation is avoided.	✓	□
■	Eliminates Erosion Damage. By controlling fluid velocities, erosion is eliminated.	✓	□

Forged Design

A fully forged one-piece Chrome Moly design eliminates the need for welding, and eliminates the risk of welds failing due to the high thermal cycling and stress of the surrounding environment.

Tapered Profile

The attemperator is designed with a tapered profile to minimize any vibrations caused by harmonic frequencies associated with vortex shedding. This becomes especially important as pipe sizes increase and the length of the attemperator increases.

No Trim in Steam Flow

Many probe designs place valve trims in the steam flow, exposing them to high steam temperatures and very large thermal stresses. The DA-90DSV moves all tight clearance trim components out of the steam flow and out of the harmful thermal environment.

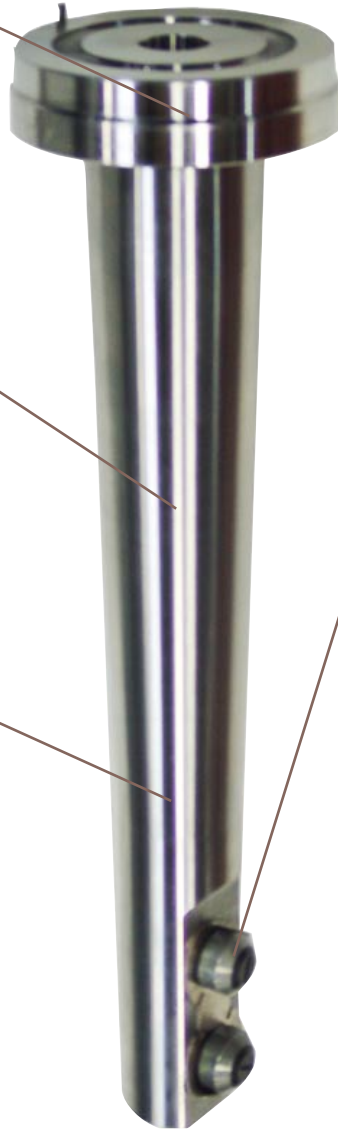

Spray Nozzle

The variable orifice spray nozzle used in the DA-90DSV provides excellent primary atomization and high rangeability. The design is proven through decades of installation in high temperature steam applications. Multiple nozzle designs (as pictured) are available for high capacity installations.



Low Flow



High Flow

Benefits	DRAG® DA-90DSV	Competition
■ Thermal Stress Analysis. CCI accounts for all thermal stresses in the attemperator design.	✓	□
■ Stops Costly Maintenance Cycles. CCI valves are designed and sized to provide longer intervals between maintenance and allows easy access to all components.	✓	□
■ Eliminate Thermal Damage to the Trim. Control element is outside of hot steam flow.	✓	□
■ Proven Desuperheating Experience.	✓	□

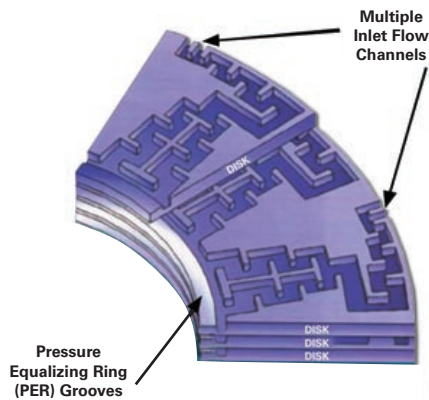

Figure 5: Each turn in the DRAG® trim is a single stage of pressure drop, eliminating potentially harmful kinetic energy.

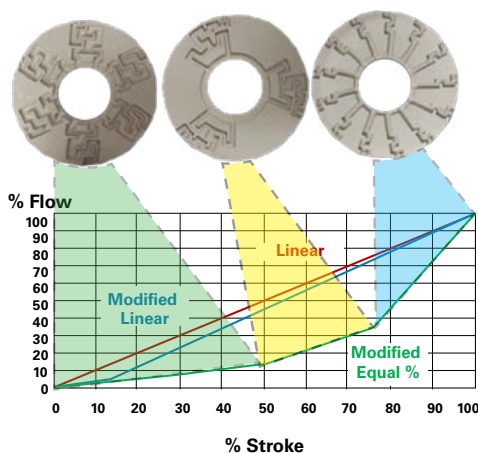
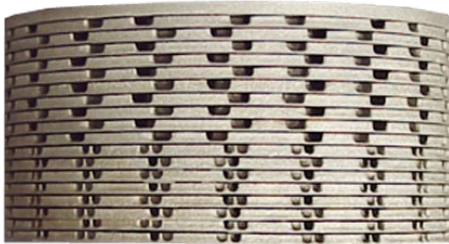

Figure 6: Characterized Equal Percentage DRAG® disk stack trim.

Eliminate Cavitation with DRAG®

DRAG® trim forces the fluid to travel through a torturous path of turns (Figure 5). Each turn causes a pressure loss in the fluid, and the pressure gradually reduces as the fluid flows through the multiple turns. This series of multiple pressure drops controls the fluid velocity and allows the pressure to reduce without falling below the vapor pressure, thus avoiding cavitation and the destruction to the valve and trim that can come with it. The DRAG® multistage pressure drop trim provides a clear benefit in terms of performance and maintenance costs when cavitation is a concern.

Accurate Control and Reliable Operation at all Flow Conditions with the CCI DRAG® Disk Stack

DRAG® disk stacks can be customized to provide the required C_v throughout the valve stroke. This is accomplished by configuring disks with various numbers of turns within the stack (Figure 6). Thus, the DRAG® control valve disk stack can be designed for many different flow characteristics, i.e. linear, equal percentage, or modified equal percentage (Figure 6). The disks at the bottom of the disk stack, close to the valve seat, are equipped with a higher number of pressure letdown stages (up to 20 stages or more) to provide critical protection of the seating surfaces on the plug and seat ring. As the valve strokes open, fewer pressure letdown stages are used for more capacity as the process requires, providing good control over the entire range of flow conditions. Independent and isolated flow paths are used to eliminate short circuits between flow paths and provide the best result in pressure letdown.

Reliable Long Term Shutoff

The DRAG® control valve uses a hard seat material and a very high seat loading to provide reliable and repeatable long term shutoff in very high pressure differential applications. The actuator is sized to provide a minimum seating load of 500 lb/in (9 kg/mm) of seat ring circumference, as recommended by ISA guidelines. The DRAG® velocity control trim design, combined with the high seating force for shut-off, protects the seating surfaces from cutting and pitting due to erosion or wire draw.

Benefits of DRAG® Velocity Control Trim

- Prevents Cavitation Damage
- Improves Plant Performance
- Eliminates Erosion Damage
- Lowers Operating Costs
- Reduces Maintenance Costs
- Reduces System Complexity
- Avoids Plant Shutdowns
- Provides Accurate Temperature Control

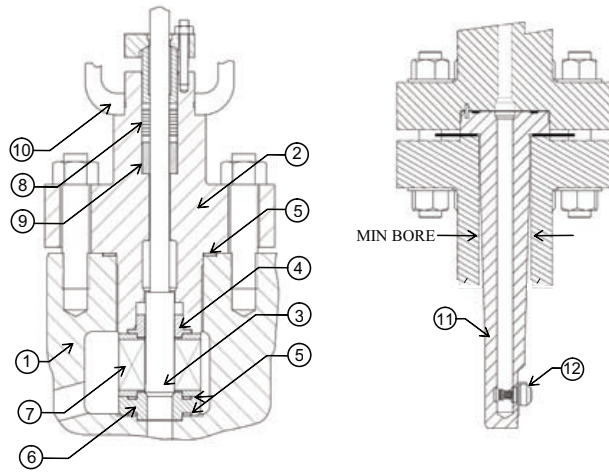
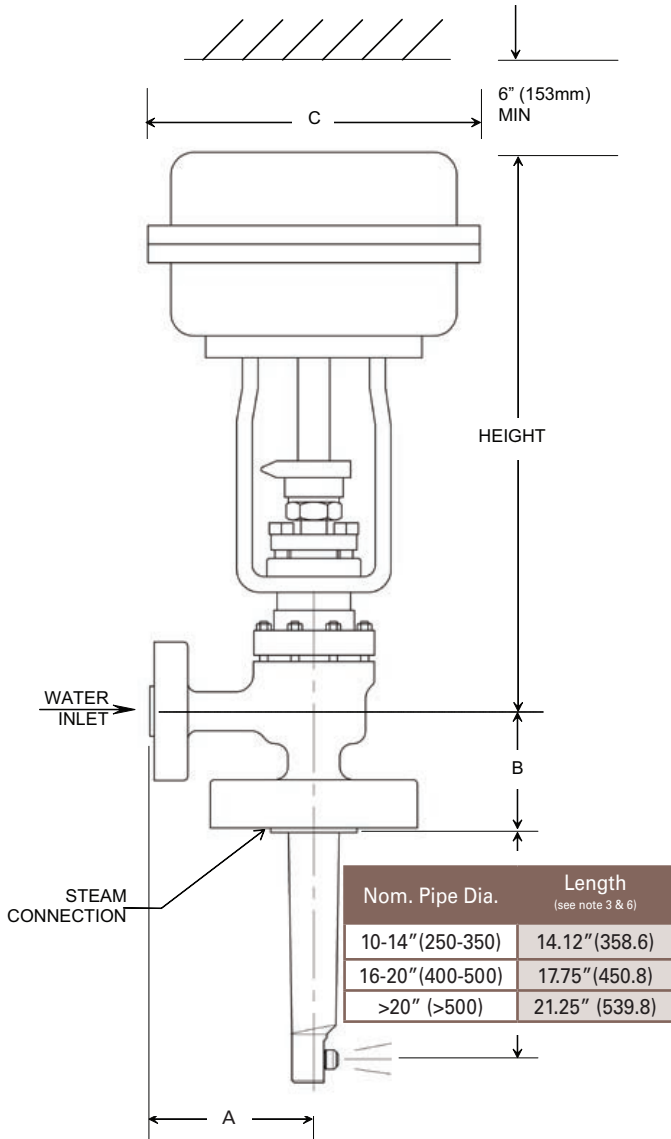

No	Name	Material
1	Body	ASME-SA217-WC9/C12A
2	Bonnet	ASME-SA182-F22/F91
3	Spindle	INCONEL 718
4	Guide Bushing	300 SS
5	Gaskets	Graphite/300 SS
6	Seat	300 SS
7	Disk Stack	INCONEL 718
8	Packing, Stem	Graphite
9	Packing, Spacer	Carbon
10	Yoke	Carbon Steel
11	Nozzle Housing	ASME-SA182-F22/F91
12	Spray Nozzle	ANSI 616

Trim Size	Water Flange	Steam Flange	ANSI	A	B	C	Dia. D ⁽⁴⁾	Height ⁽²⁾	Weight
3/8", 5/8", 1" (10, 15, 25)	1.5" RF (40)	3.0" RF (80)	600-1500	9.0" (229)	6.0" (152)	19.7" (500)	2.9" (73.7)	34" (865)	~300 lbs (140 kg)
			2500	9.5" (241)	7.0" (178)				
1.5" (40)	2.5" RF (65)	4.0" RF (100)	600-2500	12.25" (311.2)	12.25" (276.4)		3.81" (96.8)	51" (1295)	~500 lbs (230 kg)

Notes:

1. Contact factory for other sizes
2. Given is maximum; add 15" (380 mm) for manual override
3. Customer flange height will vary to center nozzle(s) in steam pipe
4. Customer supplied flanged connection
5. Numbers in brackets give dimensions in millimeters
6. Custom probe lengths available for retrofit projects



Contact us at: info@ccivalve.com

**For sales and service locations worldwide,
visit us online at: www.ccivalve.com**

Throughout the world, customers rely on CCI companies to solve their severe service control valve problems. CCI has provided custom solutions for these and other industry applications for more than 80 years.



We Solve Control Valve Problems®

DRAG is a registered trademark of CCI.
©2007 CCI 880 - 11/07 5K